



Contents

1.	Information on This Operating Instruction	1	13.	Dismounting and Disposal	14
1.1	Pictographs Used	2	14.	Warranty Conditions	14
1.2	Exclusion of Liability	2	15.	CE Conformity	14
2.	Safety Instructions	2	16.	Declaration of Conformity	15
3.	Device Description	3			
3.1	Intended Use	3			
4.	Technical Data	4			
5.	Mounting	4			
5.1	Mounting and Safety Instructions	4			
5.2	Mounting Steps for Connections According to DIN 3852	5			
5.3	Mounting Steps for G 1" Cone Connection	5			
5.4	Mounting Steps for Dairy Pipe Connections	5			
5.5	Mounting Steps for Clamp Connections	5			
5.6	Positioning of the Operating Module	6			
6.	Electrical Connection	6			
6.1	Connection and Safety Instructions	6			
6.2	Electrical Installation	7			
7.	HART® Communication	7			
8.	Commissioning	7			
9.	Operation	8			
9.1	Structure of the Menu System	8			
9.2	Menu List	9			
9.3	Configuration	11			
10.	Troubleshooting	11			
10.1	Error Messages	11			
10.2	Further Errors and Possible Measures	12			
11.	Maintenance / Cleaning, Storage and Transport	12			
12.	Recalibration and Return	13			
12.1	Recalibration	13			
12.2	Return	13			

1. Information on This Operating Instruction

- The manual is aimed at specialists and semi-skilled personnel.
- Please read the instructions carefully before carrying out any operation and keep the specified order.
- Thoroughly read and understand the information in chapter 2 "Safety Instructions".

If you have any problems or questions, please contact your supplier or contact us directly at:



ARMANO Messtechnik GmbH
Location Beierfeld
 Am Gewerbepark 9 • 08344 Grünhain-Beierfeld
 Tel.: +49 3774 58 – 0 • Fax: +49 3774 58 – 545
 mail@armano-beierfeld.com

Location Wesel
 Manometerstraße 5 • 46487 Wesel-Ginderich
 Tel.: +49 2803 9130 – 0 • Fax: +49 2803 1035
 mail@armano-wesel.com

1.1 Pictographs Used

In this manual, pictographs are used as hazard warnings.

Particular information, instructions and restrictions designed for the prevention of personal or substantial property damage:



WARNING! Is used to warn you against an imminent danger that may result in personal injury or death.

IMPORTANT! Is used to warn you against a possibly hazardous situation that may result in personal, property or environmental damage.

CAUTION! Is used to draw your attention to important recommendations to be observed. Disregarding them may result in property damage.



DANGER! This symbol is used for hazards generated by electric current. Disregarding these safety instructions may result in serious or fatal injuries.



Passages in the text containing **explanations, information or advice** are highlighted with this pictograph.



The following symbol highlights **actions** you have to conduct or **instructions** that have to be strictly observed.

1.2 Exclusion of Liability

We accept no liability for any damage or malfunction resulting from incorrect installation, inappropriate use of the device or failure to follow the instructions in this manual as well as technical regulations.

2. Safety Instructions

Please read this operating instruction thoroughly before operating the pressure transmitter.

Disregarding the containing warnings, especially the safety instructions, may result in danger for people, the environment, and the device and the system it is connected to.

The pressure transmitter corresponds with the state of engineering at the time of printing. This concerns the accuracy, the operating mode and the safe operation of the device. In order to guarantee that the device operates safely, the operator must act competently and be conscious of safety issues.

The ARMANO Messtechnik GmbH provides support for the use of its products either personally or via relevant literature. The customer verifies that our product is fit for purpose based on our technical information. The customer performs customer and application specific tests to ensure that the product is suitable for the intended use. With this verification, all hazards and risks are transferred to our customers. Our warranty expires in case of inappropriate use.

Qualified Personnel:

- The qualified personnel are those persons who are familiar with mounting, installation, commissioning, operation, maintenance, decommissioning and disposal of the product and who have an appropriate qualification for their occupation.
- This includes persons that meet at least one of the following three requirements:
 - They are aware of the safety concepts of the measurement and automation technology and are familiar therewith as project personnel.
 - They are operating personnel of measuring and automation systems and are trained in using the systems. They are familiar with the operation of the devices and technologies described in this operating instruction.
 - They are commissioning specialists or service personnel and have completed training that qualifies them to repair the system. In addition, they are authorised to commission, earth and mark circuits and devices according to the safety engineering standards.

All work with this product must be carried out by this qualified personnel!

Operating Instructions

Pressure Transmitter PTFi

General safety instructions:

- In all work, the existing national regulations for accident prevention and safety at the workplace must be complied with. Any internal regulations of the operator must also be complied with, even if these are not mentioned in this manual.
- Handle this highly sensitive electronic measuring device carefully, both in its packaged and unpackaged condition!
- Any changes or modifications to the device are not permissible.
- Do not throw or drop the device!
- Excessive dust deposits (more than 5 mm) and the complete coverage with dust must be prevented!
- The device corresponds with the state of engineering at the time of printing and is safe to operate. The device may pose residual hazards if it is used or operated improperly.

3. Device Description

The pressure transmitter PTFi is suitable for precisely measuring and monitoring vacuum, absolute pressures and positive pressures of liquid and gaseous media for pressure ranges from 0 – 400 mbar to 0 – 40 bar.

Available as process connections are hygienic connections such as clamp (standard), dairy pipe or thread connections (optional) with a flush-welded stainless steel membrane, which can be combined with a cooling extension for medium temperatures up to +300 °C, if necessary.

The robust stainless steel field housing has a high degree of protection IP67 as well as all properties for residue-free and antibacterial cleaning.

The pressure transmitter supports communication via HART® protocol. A turn-down span to 1:10 is available. A version with safety functions according to SIL2 is optionally available.

Nameplate and sticker:

The nameplate is placed on the sensor. It contains the most important technical data and information.

 ARMANO Messtechnik GmbH	
PTFi	Prod.-No.: 23456789
Instr.-No.: 203251234	<u>Connector Pinout:</u>
Input: 0...10 bar	1: +Ub Shield: Case
Supply: 12...30 VDC	3: 0V/Signal
Output: 4...20 mA/2L	 

Figure 1: nameplate PTFi

 Do not remove the nameplate from the device!

Scope of delivery:

- Pressure transmitter PTFi
- Protection cap
- For mechanical connections DIN 3852:
 - O-ring (pre-assembled)
- Operating instructions

3.1 Intended Use

- The pressure transmitter PTFi is used to convert the physical quantity pressure into an electrical signal. It is only suitable for measuring positive, negative and absolute pressures.
- The user has to check whether the respective device is suitable for the intended application. In case of doubt, please contact our sales department. The ARMANO Messtechnik GmbH accepts no liability for incorrect selection and its consequences!
- The gases or liquids specified in the data sheet can be used as measuring media. In addition, it must be ensured that the medium is compatible with the wetted parts.



WARNING!
Risk due to unintended use!

Operating Instructions

Pressure Transmitter PTFI

4. Technical Data

Process connection	clamp DN 25 (DIN 32676), stainless steel 316L (1.4435) membrane stainless steel 316L (1.4435) flush-welded
Measuring cell / sensor	stainless steel 316L (1.4435) internally welded
Case	field housing made of stainless steel 304 (1.4301), IP67, lateral display
Indication	LC display main indication (measured value): 5 digit, 7 segment indication digit height 8 mm (0.31") additional indication (unit): 8 digit, 14 segment indication digit height 5 mm (0.2") 52 segment bargraph
Output signal	4...20 mA, 2-wire current consumption max. 25 mA
Supply voltage	12...30 V DC
Signal behaviour	accuracy according to IEC 60770: $\leq \pm 0.1$ % FSO turn-down $\leq 1:5$: no changes turn-down $> 1:5$: e.g. turn-down 9: $\leq 0.1 + 0.015 \times (9 - 5)$ % FSO $= 0.16$ % FSO
Filling Liquid	food grade oil
Measurement accuracy	≤ 0.1 % FSO (including non-linearity, hysteresis and non-repeatability)
Mechanical shock	100 g / 11 ms
Mechanical vibration	max. 5 g at 25 – 2000 Hz

Measuring Ranges / Overload Capability in bar:

Vacuum / positive pressure	Positive pressure / absolute pressure	Over-pressure	Burst pressure
-0.4 / +0.4	-	2	3
-1 / +1	-	5	7.5
-1 / +2	-	10	15
-1 / +4	-	20	25
-1 / +10	-	40	50
-	0 – 0.4	2	3
-	0 – 1	5	7.5
-	0 – 2	10	15
-	0 – 4	20	25
-	0 – 10	40	50
-	0 – 20	80	120
-	0 – 40	105	210

5. Mounting

5.1 Mounting and Safety Instructions



DANGER! Risk due to electric shock!

Always mount the device in an unpressurised and currentless state! Risk of explosion, flying parts, leaking media, electric shock!

- The technical data listed in the EU type examination certificate are binding. Please download the certificate from www.armano-messtechnik.com.
- Ensure that the entire interconnection of intrinsically safe components remains intrinsically safe. The operator is responsible for the intrinsic safety of the overall system (the complete circuit).
- If there is an increased risk of damage to the device by lightning strike or overvoltage, additional lightning protection must be provided!
- Handle an unprotected membrane with extreme care; it can easily be damaged.
- Concerning outdoor installation or installation in humid environments:
 - Electrically connect the instrument immediately after installation or prevent the ingress of moisture e.g. by using a suitable protective cap (the degree of protection specified in the data sheet applies to the connected device).
 - Select an installation position that allows splash water and condensation to drain off. Ensure that sealing surfaces are not exposed to standing liquid!
 - For devices with cable gland, the outgoing cable must be routed downwards. If the cable needs to be routed upwards, this must be done in an initially downward curve.
 - Install the device in such a way that it is protected from direct sunlight. In the worst case, direct sunlight may result in the maximum permissible operating temperature being exceeded. This must be excluded if the device is used in explosion-hazardous areas!
- A device with gauge reference in the housing (small orifice next to the electrical connection) must be mounted in such a way that the gauge reference required for the measurement is protected from dirt and moisture. If the transmitter is exposed to liquid, the gauge reference will be blocked and the air pressure compensation will be prevented. In this condition, a precise measurement is not possible and the transmitter may be damaged.
- Provide a cooling extension when used in steam pipes.

Operating Instructions

Pressure Transmitter PTFi

- During installation, avoid high mechanical stresses at the pressure connection! This leads to a shift in the characteristic curve or results in damage, especially in case of very small pressure ranges and for devices with a plastic pressure connection.
- For hydraulic systems, position the device in a way that the pressure connection points upwards (ventilation).
- If the device is installed with the pressure connection facing upwards, make sure that no liquid runs down the housing. This could result in moisture and dirt blocking the gauge reference in the housing and cause malfunctions. If necessary, remove any dust and dirt from the edge of the screw fitting of the electrical connection.
- To avoid damaging the membrane and the threads, please remove the packaging and the protection caps not until installation of the device!
- The protection caps must be stored! Dispose of the packaging properly!



CAUTION!

The specified tightening torques must not be exceeded!

5.2 Mounting Steps for Connections According to DIN 3852



IMPORTANT! Do **not** use any additional sealing material such as tow, hemp or Teflon tape!

- Make sure that the O-ring is seated undamaged in the designated groove.
- Ensure that the sealing face of the mating part has a flawless surface (R_Z 3.2).
- Screw the device into the mounting thread by hand.
- If you have a device with a knurled ring, it has to be screwed in by hand only.
- Devices with a wrench flat have to be tightened with the open-end wrench:
 - wrench flat made of steel: G 1/2": approx. 10 Nm;
G 1": approx. 20 Nm; G 1 1/2": approx. 25 Nm
 - wrench flat made of plastic: max. 3 Nm

5.3 Mounting Steps for G 1" Cone Connection

- Screw the device into the mounting thread by hand (sealing achieved metallically).
- Then, tighten it with the open-end wrench:
PN < 10 bar: 30 Nm; PN ≥ 10 bar: 60 Nm

5.4 Mounting Steps for Dairy Pipe Connections

- The O-ring is seated undamaged in the designated groove.
- Centre the dairy pipe connection in the corresponding mounting part.
- Screw the union nut onto the mounting part.
- Then, tighten it with a hook wrench.

5.5 Mounting Steps for Clamp Connections

- Use a suitable sealing, depending on the medium and the pressure to be measured.
- Place the sealing onto the corresponding mounting part.
- Centre the clamp connection above the corresponding mounting part with sealing.
- Then, fasten the device using a suitable fastening element (e.g. half-ring or retractable ring clamp) according to the manufacturer's instructions.

5.6 Positioning of the Operating Module



DANGER! When opening the housing in case of explosion hazard.

Do not open the housing while there is a risk of explosion!

The display and operating module is continuously rotatable so as to guarantee easy readability even in unusual mounting positions. Proceed as follows to change the position:

- Unscrew the housing cover by hand.
- Turn the display and operating module carefully by hand into the desired position. The module is equipped with a rotational limiter.
- Before reassembling the cover, check the O-ring and sealing surface on the housing for damage and replace them if necessary!
- Then screw on the cover by hand and make sure that the housing is tightly closed again.



CAUTION!

Make sure that moisture cannot enter the device! The seals and sealing surfaces must not be soiled, as soiling can cause a reduction in the degree of protection depending on the application and location, which can lead to device failure or irreparable damage to the device!

6. Electrical Connection

6.1 Connection and Safety Instructions



WARNING! Improper installation can lead to electric shock.

Always mount the device in an unpressurised and currentless state!

- For devices with connection terminals, carry out the connection in such a way that the isolation distances comply with the standard and that the connecting lines cannot be loosened.
- For the electrical connection, use a shielded and twisted multicore cable.
- The cover for the connection terminals and display can only be opened if the locking device, a setscrew with hexagon socket, has been removed. The screw is on the right side below the cover. After attaching the cover for the display and the connection terminals, the locking device must be screwed in again. Lubrication of the threads is not necessary.
- To electrically connect the device with connection terminals, the cover has to be removed. If the device has a display and operating module, pull it out carefully. During installation, place it next to the housing strain-relieved. Afterwards, carefully reinsert it and make sure that the connecting wires are neither twisted nor pinched. Before screwing the cover back on, check the O-ring and sealing face on the housing for damage and replace them if necessary! Then, screw on the cover by hand and make sure that the field housing is firmly closed again.

Operating Instructions Pressure Transmitter PTFi

6.2 Electrical Installation

Electrically connect the instrument according to the specifications given on the nameplate, in the table below and on the wiring diagram!

Pin Assignment Table	
Electrical connections	M 12x1 metal (4-pin)
Supply +	1
Supply -	3
Shield	plug housing

Wiring diagram

2-wire system (current)

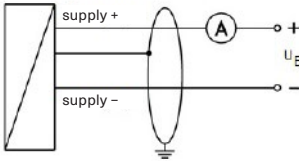

2-wire system (current) HART®

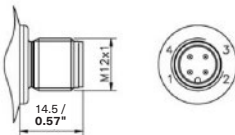
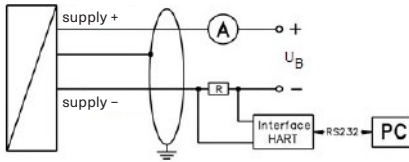

M 12x1 4-pin

7. HART® Communication

An additional signal according to the HART® specification is superimposed on the analogue output signal. The device can be configured using a communication software. In this regard, we recommend the AMS device manager by Emerson. To ensure trouble-free operation, the following specifications have to be taken into account:

Maximum cable length between measuring device and supply:

$$L_{\max} = \frac{65 \times 10^6}{R_V \times C_V} - \frac{40 \times 10^3}{C_V}$$

whereas L_{\max} : maximum length of the cable in m
 R_V : resistance of the cable together with the load resistance in Ω
 C_V : capacity of the cable in pF/m

resistance R:

$$R = \frac{U - 12}{0.024} \Omega$$

whereas U : supply in V_{DC}

The resistance must be at least 240 Ω .

8. Commissioning

- The device has been installed properly.
- The device has no visible defects.
- The device is operated within the specifications (see data sheet).

Operating Instructions

Pressure Transmitter PTFi

9. Operation

9.1 Structure of the Menu System

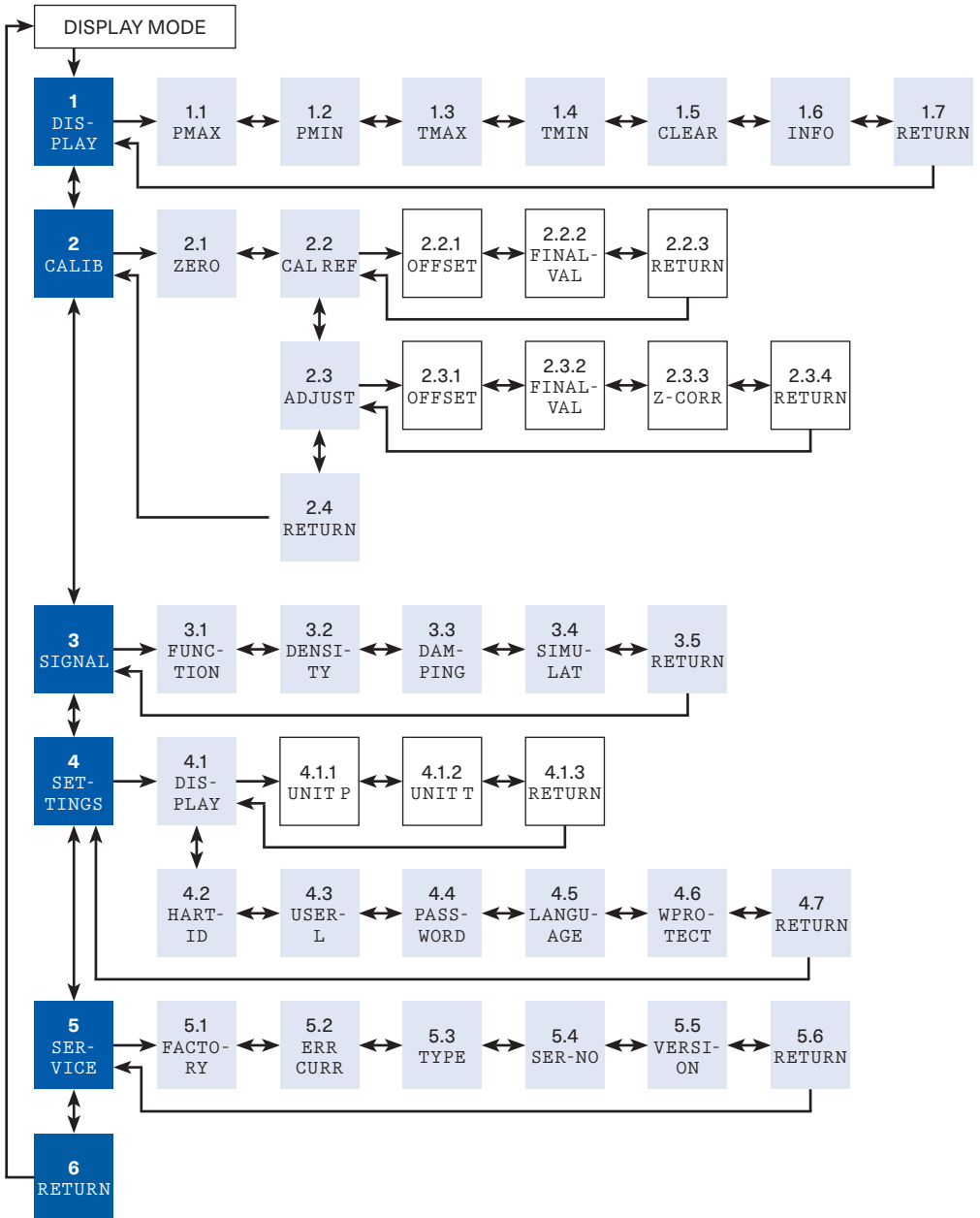

Operating Instructions

Pressure Transmitter PTFI

9.2 Menu List

1 DISPLAY	Indication Parameters
1.1 PMAx	Maximum pressure indication (high pressure) The maximum pressure that was applied during the measurement is shown in the display.
1.2 PMin	Minimum pressure indication (low pressure) The minimum pressure that was applied during the measurement is shown in the display.
1.3 TMAx	Maximum temperature indication (high temperature) The maximum temperature that was applied during the measurement is shown in the display.
1.4 TMin	Minimum temperature indication (low temperature) The maximum temperature that was applied during the measurement is shown in the display.
1.5 CLEAR	Delete the values 1.1 – 1.4 (PMAx, PMin, TMAx, TMin)
1.6 INFO	Configuration of the indication Assignment of the adjustable digits: 1: 1 st line: measured pressure 2 nd line: set pressure unit 2: 1 st line: output signal 2 nd line: mA 3: 1 st line: measured temperature 2 nd line: °C 4: 1 st line: measured pressure 2 nd line: alternation between pressure unit / output signal in mA 5: 1 st line: measured pressure 2 nd line: alternation between pressure unit / temperature in °C 6: 1 st line: measured pressure 2 nd line: alternation between pressure unit / output signal in mA / temperature in °C
1.7 RETURN	Return to menu 1 DISPLAY

2 CALIB	Configuration of Measuring Range, Indication and Output Signal
2.1 ZERO	Zeroing the indication When selecting the submenu item with the button "OK", CONFIRM appears in the display. Pressing the button "OK" for at least 2 seconds will reset the indication, and the message CONFIRM will disappear from the display.
2.2 CAL REF	Adjustment of the analogue output with pressure reference
2.2.1 OFFSET	Adjusting the initial value for the output signal After applying and accepting the reference pressure, CONFIRM appears in the display when selecting the submenu item with the button "OK". Pressing the button "OK" for at least 2 seconds will define the applied pressure as the initial value for the output signal (4 mA), and the message CONFIRM will disappear from the display. The displayed value remains unchanged.
2.2.2 FINALVAL	Adjusting the end value for the output signal After applying and accepting the reference pressure, CONFIRM appears in the display when selecting the submenu item with the button "OK". Pressing the button "OK" for at least 2 seconds will define the applied pressure as the end value for the output signal (20 mA), and the message CONFIRM will disappear from the display. The displayed value remains unchanged.
2.2.3 RETURN	Return to menu 2.2 CAL REF
2.3 ADJUST	Set measuring range and zero point
2.3.1 OFFSET	Setting the initial value of the measuring range With button "▲" or "▼" you can define an initial value of the measuring range. The permissible input range is 0...90 % of the original measuring range (turn down max. 1:10). When the entered value is reached, 4 mA are output.
2.3.2 FINALVAL	Setting the end value of the measuring range With button "▲" or "▼" you can define an end value of the measuring range. The permissible input range is 10...100 % of the original measuring range (turn down max. 1:10). When the entered value is reached, 20 mA are output.

Operating Instructions

Pressure Transmitter PTFI

2.3.3 Z - CORR	Zero point correction of indication and output signal When selecting the submenu item with the button "OK", CONFIRM appears in the display. Pressing the button "OK" for at least 2 seconds will define the applied pressure as the initial value for the output signal (4 mA), and reset the indication. The message CONFIRM will disappear from the display.	4.3 USER - L	Configuration of the security level for the user For security reasons, it is necessary to enter the password before configuring the security level. Confirm this with the button "OK". The default password is 0000. Security levels: 0: complete menu system is enabled 1: the following menu items are enabled: 1 DISPLAY, 3 SIGNAL, 4.3 USER - L 2: the following menu items are enabled: 1 DISPLAY, 4.3 USER - L
2.3.4 RETURN	Return to menu 2.2 CAL REF	4.4 PASSWORD	Configuration of the password For security reasons, it is necessary to enter the previous password before configuration. Confirm this with the button "OK". The default password is 0000. Then set the new password and confirm it with the button "OK". If you have forgotten your password, you can request the master password, which is fixed at manufacture, from If you have forgotten your password, please contact ARMANO to request the master password permanently implemented during production.
2.4 RETURN	Return to menu 2 CALIB	4.5 LANGUAGE	Selection of the operating language DE (German) or EN (English)
3 SIGNAL	Signal Parameters	4.6 WPROTECT	Write protection (HART® configuration) YES: write protection is activated, transmission of HART® commands to the storage location is not possible NO: write protection is deactivated
3.1 FUNCTION	Function selection "Linear" "2SQR" $y = \sqrt{x}$ "2SQR3POW" $y = \sqrt{x^3}$ "2SQR5POW" $y = \sqrt{x^5}$ } cut off 2 %	4.7 RETURN	Return to menu 4 SETTINGS
3.2 DENSITY	Density input adjustable range: 100...9999 kg/m ³ ; the conversion is only applicable for the units [mFH], [cmFH] and [mmFH]	5 SERVICE	Service
3.3 DAMPING	Configuration of the damping adjustable range: 0...100 s	5.1 FACTORY	Reset to factory settings
3.4 SIMULAT	Simulation of the output signal adjustable range: any, for example: 3.7...22 mA	5.2 ERR CURR	Definition of the fault current adjustable values: 21.6 mA or 3.8 mA; the selected fault current is output in the event of a malfunction of the electronics
3.5 RETURN	Return to menu 3 SIGNAL	5.3 TYPE	Indication of the device type
4 SETTINGS	Basic Settings	5.4 SER - NO	Indication of the set serial number
4.1 DISPLAY	Configuration of the display unit	5.5 VERSION	Indication of the program version (firmware)
4.1.1 UNIT P	Configuration of the pressure unit units: bar, mbar, g/cm ² , kg/cm ² , Pa, kPa, Torr, atm, mH ₂ O, ftH ₂ O, MPa, mFH*, cmFH*, mmFH*, mmH ₂ O, mmHg, psi The conversion of all pressure-related parameters is carried out automatically. *input of the density is required (see menu 3.2)	5.6 RETURN	Return to menu 5 SERVICE
4.1.2 UNIT T	Configuration of the temperature unit units: °C and °F	6 RETURN	Return to Display Mode
4.1.3 RETURN	Return to menu 4.1 DISPLAY		
4.2 HART - ID	HART-ID (only available for HART® devices in multidrop mode) Set the desired ID No. (between 0 and 15) and confirm with the button "OK". Configuration of this number is only necessary if you want to operate the unit in multidrop mode (connection of several HART® devices). If the ID No. is set to 0, the multidrop mode is deactivated and the transmitter operates in analogue mode.		

9.3 Configuration

If a parameter can be configured by means of a numerical value, each digit can be edited individually. That means after activating such a menu item (e.g. 2.3.1 OFFSET) by pressing the button "OK", the first digit of the currently set value starts flashing. Now set the desired digit with the button "▼" or "▲" and confirm it with the button "OK". Then the following digit starts flashing and can be set in the same way. In the menus 2.3.1 OFFSET and 2.3.2 FINALVAL, then the decimal point starts flashing and you can change its position with the button "▼" or "▲". By confirming the position with the button "OK", the entire value is saved if permissible. Otherwise, an error message appears in the display (e.g. Error 03) and the value is not saved. If you want to set a negative value, configure the first digit with the button "▼".

To configure the unit, unscrew the case cover by hand.



PLEASE NOTE! Make sure that moisture cannot enter the unit! Seals and sealing surfaces must not be contaminated, as contamination can cause a reduction in the degree of protection depending on the application or location and thus lead to device failure or irreparable damage to the device!



PLEASE NOTE! Prior to screwing the cover back on, check the O-ring and sealing surface on the case for damage and replace if necessary! Then screw the cover back on by hand and make sure that the case is tightly closed again.

Configuration procedure:

- To enter the operating mode, press button "▼" or "▲"
- Set the desired menu item by pressing button "▼" or "▲"
- Activate the selected menu item by pressing the button "OK"
- Set the desired value or select a default value by pressing button "▼" or "▲"
- Save / confirm a set value / a default value and exit a menu item by pressing the button "OK"

10. Troubleshooting



DANGER! Flying parts, leaking media, electric shock.

If malfunctions cannot be resolved, put the device out of service and proceed according to chapters 8 and 10!

DANGER OF EXPLOSION!

Work on live parts, except for intrinsically safe circuits, is generally prohibited while there is a risk of explosion!

In case of malfunction, check whether the device has been installed properly, in both mechanical and electrical terms. Use the following table to analyse the cause and eliminate the fault, if possible.

10.1 Error Messages

PASSED PARAMETER TOO SMALL	entered value is too small
PASSED PARAMETER TOO LARGE	entered value is too large
LOOP CURRENT NOT ACTIVE	loop current is not active (HART-ID > 0, device operates in multidrop mode)
APPLIED PROCESS TOO LOW	applied pressure is too low
APPLIED PROCESS TOO HIGH	applied pressure is too high
LOWER RANGE VALUE TOO HIGH	lower range value (OFFSET) is too high
LOWER RANGE VALUE TOO LOW	lower range value (OFFSET) is too low
UPPER RANGE VALUE TOO HIGH	upper range value (FINALVAL) is too high
UPPER RANGE VALUE TOO LOW	upper range value (FINALVAL) is too low
SPAN TOO SMALL	span is too small
DEVICE MALFUNCT	internal communication fault; please send the device to ARMANO for repair

10.2 Further Errors and Possible Measures

Fault: Display does not work

Possible cause	Fault detection / measures
incorrectly connected	check the connections
line break	check all connecting lines
defective power supply	check the power supply unit and the supply voltage applied to the transmitter

Fault: no output signal

Possible cause	Fault detection / measures
incorrectly connected	check the connections
line break	check all connecting lines
defective measuring instrument (signal input)	check the amperemeter (microfuse) or the analogue input of your signal processing unit

Fault: analogue output signal too low

Possible cause	Fault detection / measures
load resistance too high	check the value of the load resistance
supply voltage too low	check the output voltage of the power supply unit
defective power supply	check the power supply unit and the supply voltage applied to the transmitter

Fault: small shift of the output signal

Possible cause	Fault detection / measures
membrane of the measuring cell is highly contaminated, calcified or encrusted	check the membrane; if necessary, send the device to ARMANO for cleaning

Fault: large shift of the output signal

Possible cause	Fault detection / measures
membrane of the measuring cell is damaged (caused by overpressure or mechanically)	check the membrane; in case of damage, send the device to ARMANO for repair

Fault: measured value (display and analogue output) deviates from the reference value

Possible cause	Fault detection / measures
overpressure / pressure shocks	recalibration or replacement of the pressure connection by ARMANO is required
mechanical damage of the membrane	

Fault: constant output signal at 4 mA

Possible cause	Fault detection / measures
wrong ID number	make sure that the set value under menu item ID is 0000

11. Maintenance / Cleaning, Storage and Transport



CAUTION! Material damage and loss of warranty!

Any modifications or interventions in the device, made by the customer, might damage important parts or components. Such intervention leads to the loss of any warranty and manufacturer's responsibility!

→ Never modify the device or perform any repairs yourself.

Maintenance:

In principle, the device is maintenance-free. If necessary, the housing of the device can be cleaned with a damp cloth and a non-aggressive cleaning solution when switched off.

Cleaning:

Depending on the medium, deposits or contamination may occur on the membrane. If such a tendency of the medium is known, the operator has to specify appropriate cleaning intervals.

After professionally decommissioning the instrument, the membrane can usually be cleaned carefully with a non-aggressive cleaning solution and a soft brush or sponge. If the membrane is calcified, it is recommended to have the decalcification carried out by the ARMANO Messtechnik GmbH. Please also refer to chapter 12.2 "Return".



CAUTION! Incorrect cleaning may cause irreparable damage of the measuring cell.

Therefore, never use any sharp objects or compressed air for cleaning the membrane.



IMPORTANT! Improper transport can destroy the device and cause considerable personal and property damage.

Please inspect the transport packaging and the delivered items immediately upon their receipt to determine their integrity, completeness and conformity with the delivery documents.

The permissible ambient conditions for storage and transport can be found in the data sheet.

Storage:

- If possible, store the instrument in its original packaging.
- If possible, remove the packaging not until installation of the device.
- Store the instruments in a dry place, not exposed to direct sunlight.
- The storage temperature of the instruments should not fall below or exceed the permissible temperature limitations specified in the data sheets.

Transport:



Electronic components!

The device is equipped with sensitive electronic components and has to be handled with due care.

- Use the original packaging or comparable packaging for transport.
- Avoid impacts or strong vibrations.
- Protect the device against moisture.

12. Recalibration and Return

12.1 Recalibration

The offset value or range value may shift during the service life of the device. In this regard, it appears that a deviating signal value in relation to the set lower or upper range value is displayed. If either of these two phenomena occurs after prolonged use, recalibration is recommended to ensure continued high accuracy.

12.2 Return

Prior to any return, whether for recalibration, decalcification, for modification or for repair, the instrument has to be cleaned thoroughly and packaged carefully. Please enclose a notice of return with a detailed description of the faults when returning a defective device. If your instrument came into contact with harmful substances, a declaration of contamination is required additionally. A corresponding template can be found on our website www.armano-messtechnik.com. If you send in your device without a declaration of contamination and our service department has doubts regarding the medium used, then the repair will only be started once a corresponding declaration has been submitted.



WARNING! Risk of injury due to harmful substances!

If the device came into contact with harmful substances, appropriate precautions are to be taken during cleaning!

Operating Instructions

Pressure Transmitter PTFi

13. Dismounting and Disposal



WARNING! Risk of injury!

Never remove the device from a system in operation.

Make sure that the system is switched off professionally.

Before dismounting:

Check before dismounting, whether the system

- is switched off,
- is in a safe and currentless state,
- is unpressurised and cooled down.

Dismounting:

Pay attention to potentially leaking media. Take appropriate precautions to collect them.

Disposal:

In compliance with the directives 2011/65/EU (RoHS) and 2012/19/EU (WEEE), the device must be disposed of separately as electrical and electronic waste. Please regard legal regulations of the country of distribution.



NO DOMESTIC WASTE!

The instrument comprises various materials. It shall not be disposed of together with domestic waste.

→ Bring the device to your local recycling plant

or

→ send the device back to your supplier or to the ARMANO Messtechnik GmbH.

14. Warranty Conditions

The warranty conditions are subject to the statutory warranty period of 24 months, valid from the date of delivery.

Any warranty claims are excluded in case of improper use, modification of or damage to the device. Damaged membranes are not accepted as warranty claim. Furthermore, defects resulting from normal wear are not subject to warranty services.

15. CE Conformity



The CE marking of the instruments certifies the conformity with prevailing EU directives for placing products on the market within the European Union. The following directives apply:

2014/30/EU (EMC)

2014/68/EU (PED)

The corresponding declaration of conformity is enclosed or available upon request.

16. Declaration of Conformity

EU-Konformitätserklärung

EU Declaration of Conformity

Für die nachfolgend bezeichneten Erzeugnisse

We hereby declare for the following named goods

DRUCKMESSUMFORMER
Typ PTPi
gemäß Datenblatt 9711

PRESSURE TRANSMITTER
Model PTPi
according to data sheet 9711

DRUCKMESSUMFORMER
Typ PTFi
gemäß Datenblatt 9712

PRESSURE TRANSMITTER
Model PTFi
according to data sheet 9712

DIFFERENZDRUCKMESSUMFORMER
Typ PTDi
gemäß Datenblatt 9721

DIFFERENTIAL PRESSURE TRANSMITTER
Model PTDi
according to data sheet 9721

wird hiermit erklärt, dass sie den wesentlichen Schutzanforderungen entsprechen, die in nachfolgend bezeichneten Richtlinien festgelegt sind:

that they meet the essential protective requirements, which have been fixed in the following directives:

RICHTLINIE 2014/30/EU DES EUROPÄISCHEN PARLAMENTS UND DES RATES vom 26. Februar 2014 zur Angleichung der Rechtsvorschriften der Mitgliedstaaten über die elektromagnetische Verträglichkeit – kurz: **EMV-Richtlinie**
Konformitätsbewertungsverfahren: Modul A
Angewandte Norm: EN 61326-1:2013

DIRECTIVE 2014/30/EU OF THE EUROPEAN PARLIAMENT AND THE COUNCIL from February 26, 2014 on the approximation of the laws of the Member States relating to the electromagnetic compatibility – short: **EMC Directive**
Conformity assessment procedure: Module A
Applied standard: EN 61326-1:2013

RICHTLINIE 2011/65/EU DES EUROPÄISCHEN PARLAMENTS UND DES RATES vom 08. Juni 2011 zur Beschränkung der Verwendung bestimmter gefährlicher Stoffe in Elektro- und Elektronikgeräten – kurz: **RoHS-Richtlinie**
Konformitätsbewertungsverfahren: Modul A, gemäß dem Beschluss Nr. 768/2008/EC
Angewandte Norm: EN 50581:2012

DIRECTIVE 2011/65/EU OF THE EUROPEAN PARLIAMENT AND THE COUNCIL from June 8, 2011 on the restriction of the use of certain hazardous substances in electrical and electronic equipment – short: **RoHS Directive**
Conformity assessment procedure: Module A, according to Decision No. 768/2008/EC
Applied standard: EN 50581:2012

Des Weiteren fallen diese Geräte mit einem Druckmessbereich >0,5 bar als „druckhaltende Ausrüstungsteile“ unter die:

Moreover, these instruments with a pressure range >0.5 bar are, as pressure equipment parts, subject to

RICHTLINIE 2014/68/EU DES EUROPÄISCHEN PARLAMENTS UND DES RATES vom 15. Mai 2014 zur Angleichung der Rechtsvorschriften der Mitgliedstaaten betreffend Druckgeräte – kurz: **Druckgeräterichtlinie**

DIRECTIVE 2014/68/EU OF THE EUROPEAN PARLIAMENT AND THE COUNCIL from May 15, 2014 on the approximation of the laws of the Member States relating to pressure equipment – short: **Pressure Equipment Directive**

Die Geräte werden nach geltender guter Ingenieurpraxis ausgelegt und gefertigt.
Mit Messbereichen ab 0 – 200 bar wurden sie folgendem Konformitätsbewertungsverfahren unterzogen:

These instruments are designed and manufactured according to sound engineering practice.
Versions with pressure ranges from 0 – 200 bar are subjected to the following conformity assessment procedure:

Modul A „Interne Fertigungskontrolle“

Module A “Internal Production Control”

Soweit zutreffend erstreckt sich die CE-Kennzeichnung dann auch auf diese Richtlinie

As far as they are concerned, the CE-marking then also applies to this directive.

Diese Erklärung wird verantwortlich für den Hersteller:
This declaration is issued under the sole responsibility of the manufacturer:

ARMANO Messtechnik GmbH
abgegeben durch/by
Grünhain-Beierfeld, 2021-04-14



Bernd Vetter
Geschäftsführender Gesellschafter / Managing Director



ARMANO Messtechnik GmbH
Standort Beierfeld
Am Gewerbehof 9
08344 Grünhain-Beierfeld
Tel.: +49 3774 58 – 0
Fax: +49 3774 58 – 545
mail@armano-beierfeld.com

Standort Wesel
Manometerstraße 5
46487 Wesel-Ginderich
Tel.: +49 2803 9130 – 0
Fax: +49 2803 1035
mail@armano-wesel.com

Operating Instructions

Pressure Transmitter PTFi



ARMANO Messtechnik GmbH

Location Beierfeld

Am Gewerbepark 9
08344 Grünhain-Beierfeld
Tel.: +49 3774 58 – 0
Fax: +49 3774 58 – 545
mail@armano-beierfeld.com

Location Wesel

Manometerstraße 5
46487 Wesel-Ginderich
Tel.: +49 2803 9130 – 0
Fax: +49 2803 1035
mail@armano-wesel.com